

JPE 8-4-3

A Novel Grid-Connected PV PCS with New High Efficiency Converter

Byung-Duk Min[†], Jong-Pil Lee^{*}, Jong-Hyun Kim^{*}, Tae-Jin Kim^{*}, Dong-Wook Yoo^{*},
Kang-Ryoul Ryu^{**}, Jeong-Joong Kim^{**} and Eui-Ho Song^{**}

^{†*}Korea Electrotechnology Research Institute, Changwon, Korea

^{**}Changwon National University, Changwon, Korea

ABSTRACT

In this paper, new topology is proposed that can dramatically reduce the converter power rating and increase the efficiency of total PV system. Since the output voltage of PV module has very wide voltage range, in general, the DC/DC converter is used to get constant high DC voltage. According to analysis of PV characteristics, in proposed topology, only 20% power of total PV system power is needed for DC/DC converter. DC/DC converter used in proposed topology has flat efficiency curve at all load range and very high efficiency characteristics. The total system efficiency is the product of that of converter and that of inverter. In proposed topology, because the converter efficiency curve is flat all load range, the total system efficiency at the low power range is dramatically improved. The proposed topology is implemented for 200kW PCS system. This system has only three DC/DC converters with 20kW power rating each other. It is only one-third of total system power. The experiment results show that the proposed topology has good performance.

Keywords: Photovoltaic, PCS, High efficiency, Grid-connected inverter

1. Introduction

Renewable energy resources will be an increasingly important part of power generation in the new millennium. Besides assisting in the reduction of the emission of greenhouse gases, they add the much needed flexibility to the energy resource mix by decreasing the dependence on fossil fuels. Due to their modular characteristics, ease of installation and because they can be located closer to the user, PV systems have great potential as distributed power

source to the utilities.

This paper deals with new topology of grid connected PV PCS. In Chapter 2, the comparison to the several topologies is fulfilled. In chapter 3, PV characteristics are described. In chapter 4, new topology is proposed and analyzed from the point of view of power rating and efficiency. In the chapter 5, the implementation and experimental data are presented to prove the usefulness of the proposed topology.

2. General Topology for PV PCS

Figure1 shows the general topologies of photovoltaic PCS. Figure1 (a) consists of inverter and line frequency transformer. In general, PV module has wide voltage

Manuscript received May 23, 2008; revised June 18, 2008

[†]Corresponding Author: badmin@keri.re.kr

Tel: +82-55-280-1434, Fax: +82-55-280-1339, KERI

^{*}Electric Power Research Division, KERI

^{**}Changwon National University

variation range. The output voltage of inverter is restricted by the lowest PV input DC voltage. Therefore, the output voltage of inverter is much lower than grid voltage. To increase the output voltage of inverter is used the low frequency transformer. The advantage of this topology is simple. The disadvantage is very heavy and huge because of large line frequency transformer and the inverter power switches like IGBTs with large current ratings are needed to get designed power rating because of low output voltage of inverter. The large current is also not good for the system efficiency.

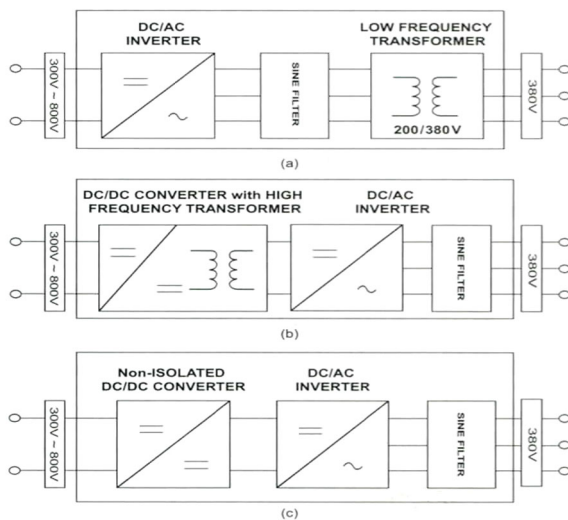

Fig. 1 The topologies of photovoltaic PCS

The topology that overcomes the disadvantages of Figure 1(a) using high frequency transformer is shown in Figure 1(b). In this case, at first, PV DC input voltage is boosted to the constant dc voltage by DC/DC converter and then the inverter generates the grid voltage using boosted high constant dc voltage. In this topology, the system size, cost and weight can be reduced dramatically because the high frequency transformer is used, and because DC input voltage of inverter is high enough to directly generate the grid voltage, the current rating of power switches of inverter is much lower than that of the power switches of Figure 1(a). But this system has also disadvantages. For high efficiency, DC/DC converter with very high efficiency is needed. Because the power rating of DC/DC converter is the same as that of total system, for high power system, DC/DC converter has also high power rating. The PV PCS using non-isolated converter is shown

in Figure 1(c). This topology is very simple because the transformer for isolation is not used. In recent, this type PCS is popular because of small system size, high efficiency and low cost. The disadvantages of this topology are the same as those of Figure 1(b) topology. Figure 1(b) and Figure 1(c) system have many advantages but it is not good for high power PCS system because the converter power rating must be the same as the total system power.

3. Characteristics of PV Modules

The output characteristic of PV cell is affected by irradiation and operating temperature. Figure 2 shows the PV output characteristics of PV module. At the constant temperature, if the irradiation is increased, the output power is increased. At the constant irradiation conditions, if the temperature is decreased, the output power is increased. It can be seen in figure 2 that the output voltage of PV module should be controlled in appropriate level to obtain maximum power from PV module. We call it as maximum power point tracking (MPPT). Another characteristic of PV module is that at the low output voltage, the output power is reduced significantly even if the irradiation is high. To connect the output of PV PCS to the grid, PV PCS must generate higher voltage than that of grid. In the Figure 2, it can be seen that the output voltage varies wide voltage range according to irradiation and temperature. Therefore to connect PV PCS to the grid, some technique is needed to increase the output voltage of PV PCS like boost transformer, DC/DC converter to increase the input DC voltage of inverter.

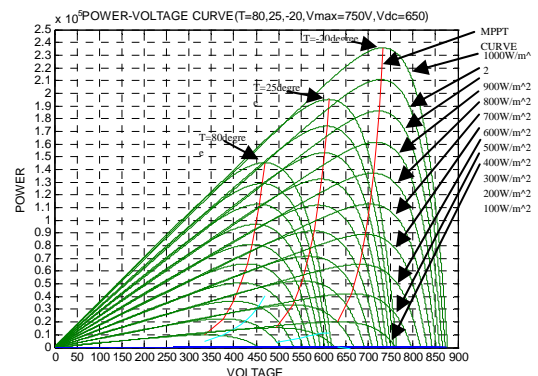

Fig. 2 Characteristics of PV module

4. New Topology for PV PCS

In general, since the lowest voltage of PV module is lower than required voltage to connect to the grid directly, there is always some difference between the PV module output voltage and the required DC link voltage. In the other point of view, to obtain the required DC link voltage, it is possible if this difference voltage is added to the PV module output dc voltage. Figure 3 shows the new proposed topology to get high DC link voltage. The small isolated dc/dc converter generates only the difference voltage between the PV module voltage and the required DC link voltage of inverter. Therefore, since DC/DC converter must not generate the whole required voltage in the proposed topology, the required power capacity of DC/DC converter is reduced dramatically. Since the output side of proposed DC/DC topology is connected in series with PV module, the current is flowing through DC/DC converter and PV module commonly.

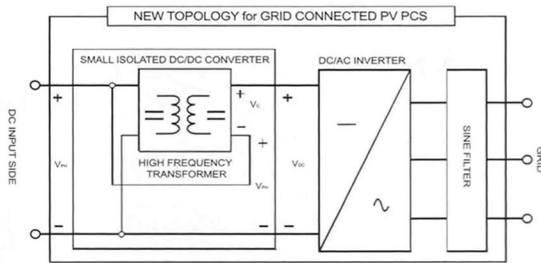

Fig. 3 Proposed topology for PV PCS

Figure 4 shows the concept of the proposed topology. The DC link power is described as follows

$$P_{DC} = V_{DC}I_{DC} = V_c I_{DC} + V_{PH}I_{DC} = P_c + P_{PHDC} \tag{1}$$

Where P_c is converter power, P_{PHDC} is PV power on the DC link side. The ratio of the sharing power of converter is the ratio of the converter output voltage, V_c and DC link voltage V_{DC} . The larger the difference between PV module output voltage and the required DC link voltage is, the larger the converter power is. The closer PV module output voltage is to the required DC link Voltage, the power of converter is reduced rapidly.

In Figure 2, cyan line means the required converter

power. The maximum power point of converter is at the maximum operating temperature point and maximum irradiation point. The required maximum converter power can be calculated as follows

$$I_{DCTM} = \frac{P_{PHTM}}{V_{DC}}$$

$$P_c = I_{DCTM}(V_{DC} - V_{PHTM}) \tag{2}$$

$$= P_{PHTM} \frac{V_{DC} - V_{PHTM}}{V_{DC}}$$

Where V_{PHTM} is the PV module output voltage at the maximum operating temperature, P_{PHTM} is PV module output power at the maximum operating temperature. The developed PV PCS specifications are as follows

MPPT range : $450V \sim 850V_{DC}$,

Max. operating Temperature of PV module : $80^\circ C$,

Required DC link voltage of inverter : $650V_{DC}$,

The output voltage of inverter : $380V_{AC}$,

Rated PCS power = 200kW.

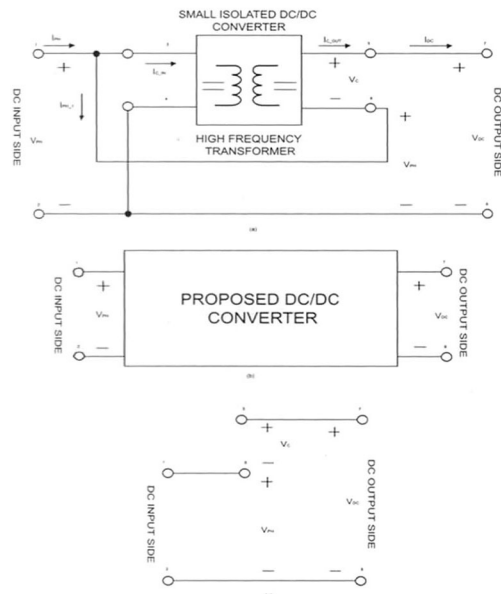

Fig. 4 Explanatory diagram of the proposed topology (a) main block diagram, (b) input/output block diagram, (c) the concept of the proposed topology

Using above equations and specifications, the maximum power of converter is obtained as follows

$$V_{PHTM} = 470V(\text{from Figure 2 at Max. Temp}),$$

$$P_{PHTM} = 145kW(\text{from Figure 2 at Max. Temp}),$$

$$P_c = 145kW \frac{650V - 470V}{650V} = 40.15kW$$

This converter power is only 20% of the required PCS power. In the proposed topology, the required converter power is dramatically reduced. The efficiency flow diagram is shown in figure 5. Figure 5(a) shows the efficiency flow of conventional topology. The total efficiency is the product of efficiency of converter and that of inverter. Therefore, the total efficiency is affected to that of converter mainly. But the proposed topology has a different efficiency flow from conventional topology as shown in figure 5(b). The proposed converter efficiency is described as follows:

$$\eta_i = p + (1 - p)\eta_c$$

$$p = \frac{P_s - P_c}{P_s}$$
(3)

Where

- η_i : the total efficiency of proposed converter
- p : the ratio from PV module directly
- P_s : Total system power of system
- P_c : DC / DC converter power.

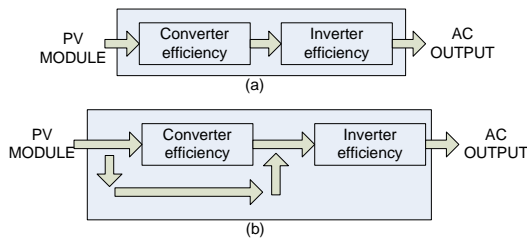

Fig. 5 Efficiency flow diagram
(a) conventional DC/DC converter + inverter topology, (b) proposed topology

In small power sharing region at the DC/DC converter, the most power is directly provided by PV module to the load, the total efficiency of proposed converter is very high. The total PV PCS system efficiency is described as follows

$$\eta_s = \eta_i \cdot \eta_c$$
(4)

Where η_s is total PV PCS efficiency, η_i is inverter efficiency. Figure 6 shows the topologies for high power PV PCS. Figure 6(a) uses the large low voltage transformer because there is no DC/DC converter. In general, high power DC/DC converter with 200kW power rating is very difficult to make. But using proposed topology, the implementation of converter with high efficiency is easy since small power capacity of converter is required.

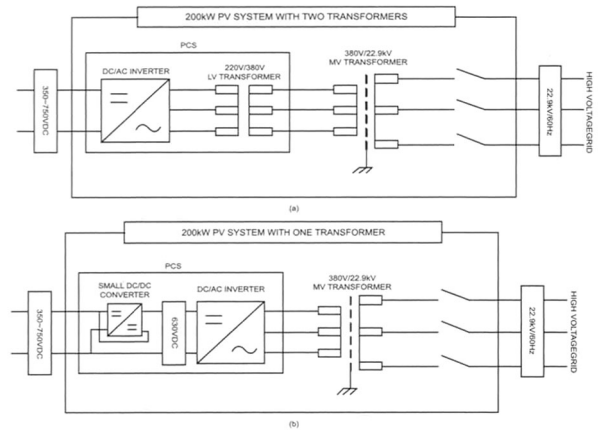

Fig. 6 Comparison to the two topologies
(a) using low voltage line frequency transformer
(b) using proposed topology

5. Experimental Results

The proposed system is implemented as shown in figure 7. Three DC/DC converters with 25kW power capacity each other are used to boost DC voltage. The specifications of DC/DC converter are as follows

- Input voltage range : 450V~850V
- Output voltage range : 0~200V
- One module power : 25kW
- Max. output current of module : 130A
- Total max. output current : 390A (130A x 3)
- Total converter power : 75kW(25kW x 3).

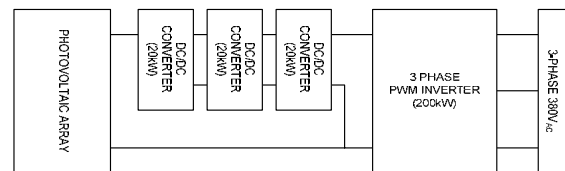
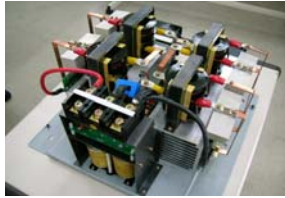

Fig. 7 System diagram of 250kW grid connected PV PCS

The specifications of PV PCS system are as follows

- Rated Power : 250kW
- MPPT range : 450V ~ 850V
- Output Voltage : 380V_{rms}
- Minimum DC link voltage of inverter : 650V



(a)



(b)

Fig. 8 Implemented PV system with the proposed topology (a) DC/DC converter, (b) inverter

Figure 8 shows the implemented system with the proposed topology. This system has three DC/DC converters. This prototype has low voltage transformer. In proposed system, the low voltage transformer is option since the DC link voltage of inverter is high enough to provide the higher ac voltage than that of grid. Some power company requires the isolation transformer. In low power PV PCS system, non-isolated PV PCS system is used widely because that system is small and cheap.

The efficiency of proposed DC/DC boost topology is shown in Figure 9. Blue line is the efficiency curve of the small DC/DC converter. The red line is total efficiency of the proposed converter topology. We can see that the

efficiency curve is flat for all load range. In figure 9, x-axis means the PV module output voltage. If PV module output voltage is high, the power sharing of DC/DC converter is low, i.e. the DC/DC converter is in the light load state. If PV module output voltage is low, the power sharing of DC/DC converter is high because the voltage difference between target DC link voltage and PV module voltage is large, i.e. the DC/DC converter is in the heavy load state. In general, at light load state, the efficiency is low. At heavy load state, that is high. But as explained before, the total efficiency is flat with no relation to the load state of converter.

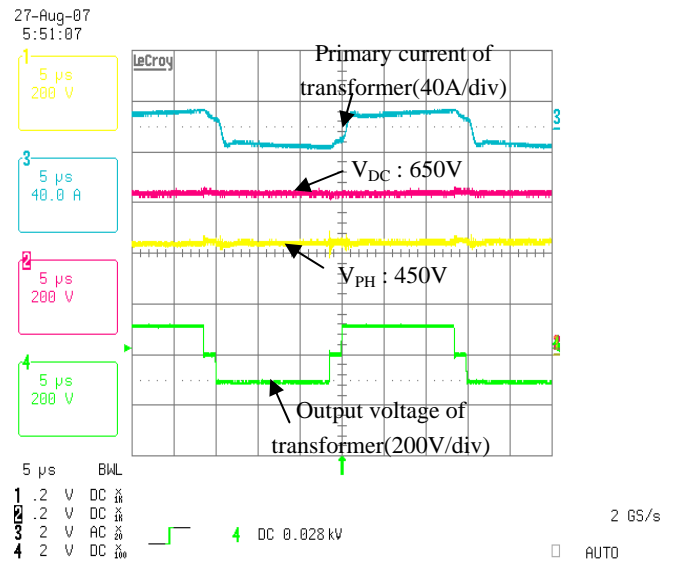

(a)

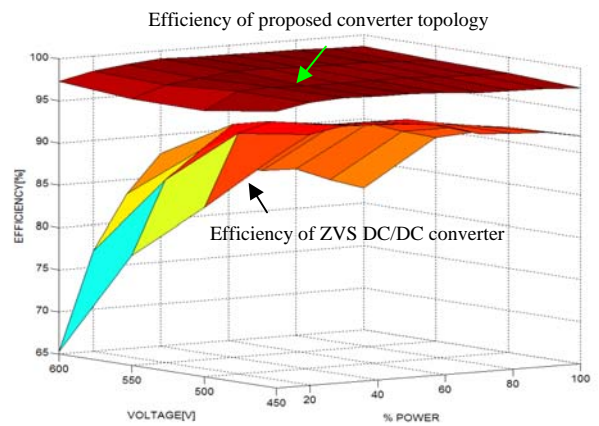

(b)

Fig. 9 The experimental results of proposed converter (a) waveforms of proposed converter (b) Efficiency map of proposed converter

Figure 10 shows the inverter output current (red line) and grid voltage (blue line) waveforms. The output power of PCS is 100kW, THD of line currents is 3.8%.

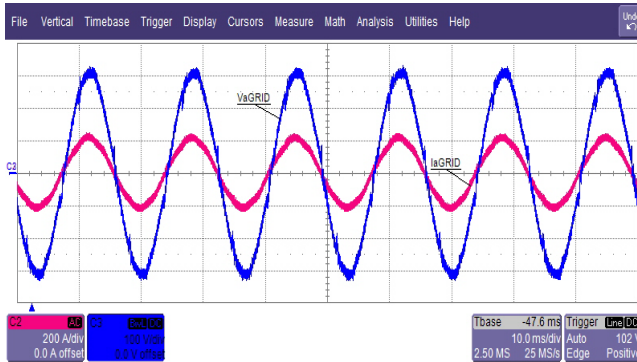

Fig. 10 Experimental waveforms (blue : grid voltage, 100V/div, red : inverter output current, 200A/div)

Figure 11 shows the total system efficiency curve. Using general DC/DC converter, the total efficiency is very low at the low load condition. But using the proposed converter topology, the total efficiency of inverter/converter system is very high in spite of low efficiency of general DC/DC converter.

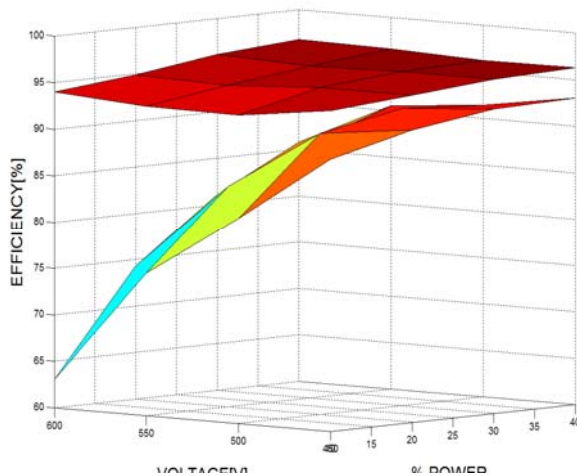

Fig. 11 Experimental total system efficiency curve

6. Conclusions

In this paper, new topology for PV PCS was proposed. The proposed topology has the flat efficiency curve throughout all load range at the converter part and the

required DC/DC converter power capacity is only 20% of total rated power of PV PCS. The implementation burden of high power DC/DC converter is low. Therefore the proposed topology can be applied to all power rating PCS. Since DC link voltage can be boosted enough to provide the AC voltage higher than that of grid using the proposed topology, the current rating of IGBT is half of that of conventional PCS with low DC link voltage. It was shown that the proposed topology had good performance through experimental results.

References

- [1] Kasemsan Siri, Vahe A. Caliskan, C. Q. Lee, "Maximum Power Tracking in Parallel Connected Converters", *IEEE Transaction on Aerospace and Electronic systems*, Vol. 29, No. 3, July 1993.
- [2] Mummadi Veerachary, Tomonobu Senjyu, Katsumi uezato, "Voltage-Based Maximum Power Point Tracking Control of PV System", *IEEE Transactions of Aerospace and Electronic Systems*, Vol. 38, No. 1, January 2002.
- [3] Guo-Kiang Hung, Chih-Chang Chang, Chern-Lin Chen, "Automatic Phase-Shift Method for Islanding Detection of Grid-Connected Photovoltaic Inverters", *IEEE Transactions on Energy Conversion*, Vol. 18, No. 1, March 2003.
- [4] S. Alepuz, S. Busquets-Monge, J. Bordonau, J. Gago, D. Gonzalez, J. Balcells, "Interfacing Renewable Energy Sources to the Utility Grid Using a Three-Level Inverter", *IEEE Trans. on Industrial Electronics*, Vol. 53, No. 5, pp. 1504-1511, Oct. 2006.
- [5] H. Koizumi, T. Mizuno, T. Kaito, Y. Noda, N. Goshima, M. Kawasaki, K. Nagasaka, K. Kurokawa, "A Novel Microcontroller for Grid-Connected Photovoltaic Systems", *IEEE Trans. on Industrial Electronics*, Vol. 53, No. 6, pp. 1889-1897, Dec. 2006.
- [6] Amir Ostadi, Xing Gao, Gerry Moschopoulos, "Circuit Properties of Zero-Voltage-Transition PWM Converters", *Journal of Power Electronics*, Vol. 8, No. 1, pp. 35-50, Jan. 2008.
- [7] Bhim Singh, Ganesh Dutt Chaturvedi, "Analysis, Design, Modeling, Simulation and Development of Single-Switch AC-DC Converters for Power Factor and Efficiency Improvement", *Journal of Power Electronics*, Vol. 8, No. 1, pp. 51-59, January 2008.
- [8] Sirukarumbur Panduranfngan Natarajan, Thangavel Saroja Anandhi, "Control of Input Series Output Parallel Connected DC-DC Converters", *Journal of Power Electronics*, Vol. 7, No. 3, pp. 265-270, July 2007.

- [9] Kyung-soo Lee, Kenichiro Yamaguchi, Kosuke Kurokawa, "Proposed Distribution Voltage Control Method for Connected Cluster PV Systems", *Journal of Power Electronics*, Vol. 7, No. 4, pp. 286-293, Oct. 2007.
- [10] Weidong Xiao, Ozog, N., Dunford, W.G., "Topology Study of Photovoltaic Interface for Maximum Power Point Tracking", *IEEE Transactions on Industrial Electronics*, Vol. 54, No. 3, pp. 1696-1704, June 2007.



Byung-Duk Min received the B.S. degree in electronic Engineering at Kyungbook National University in 1990 and received the M.S. and Ph.D. degrees in electronic and electrical Engineering at POSTECH in 1992, 1997, in South Korea, respectively. He worked for Hyundai Electronics Industries and Hyundai Heavy Industries at the Electric and Hybrid Vehicle Research part from 1997 to 2004. He is currently working as a senior researcher in the power conversion and system for RES (renewable energy sources) research group of Korea Electro-technology Research Institute (KERI) from 2005, Korea. His main research interests are Photovoltaic PCS, photovoltaic simulator, UPS, induction & PMSM Motor driver, and hybrid electric vehicle driver.

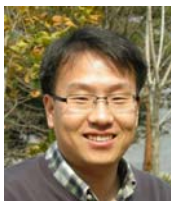

Jong-Pil Lee received the B.S., M.S. in Control and Instrumentation of Engineering and Electrical Engineering from Korea University, Korea in 1997 and 1999 respectively. He is currently working toward the Ph.D. degree in electrical engineering at Korea University, Seoul. From 1999 to 2005, he was a senior researcher at Hyundai Heavy Industries at the Electric and Hybrid Vehicle Research part. He is working as a senior researcher in the power conversion and system for RES (renewable energy sources) research group of Korea Electro-technology Research Institute (KERI) from 2006, Korea. His main research interests are Photovoltaic PCS, ZVS DC/DC converter, Power Conversion for Hybrid Electrical Vehicle.



Jong-Hyun Kim received the BS degree in electronic engineering at Kyungbook National University in 1991 and received the MS and Ph.D. degrees in electronic and electrical Engineering, at Pohang University of Science and Technology in 1994, 1998, respectively. He worked for power electronics team, Samsung Electro Mechanics from 1998 to 2002. His main research interests are pulsed power supply, semiconductor stacking, and

module type power converter. He is currently a senior researcher in power electronics group, KERI.

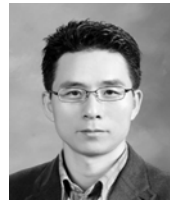

Tae-Jin Kim received the B.S., M.S., and Ph.D degrees in electrical engineering from Pusan National University, Korea, in 1994, 1997 and 2007, respectively. From 1995 to 1996, he was a researcher in the Superconductivity Research Center, Osaka University, Japan. He has been with Renewable Research Group at Korea Electro-technology Research Institute since 1997, where he is currently a senior researcher. His main research interests are Fuel cell PCS, high current power conversion system for arc welding machine.



Dong-Wook Yoo received received the B.S. degree in electrical engineering from Sung-Kyun-Kwan University (SKKU), Suwon, Korea, in 1983, the M.S. degree in electrical engineering from Yon-Sei University, Seoul, Korea, in 1985, and the Ph. D. degree, majoring in power electronics, from SKKU in 1997. He became a Researcher in 1985, Senior Researcher in 1989, Principal researcher in 1997 at Korea Electrotechnology Research Institute (KERI), Changwon, Korea. Since 1997, he was a Team Leader of Power Electronics Laboratory, and Renewable Energy Laboratory at KERI.

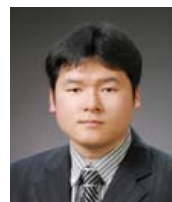

Kang-Ryul Ryu was born in Korea in 1979. He received his B.S. and M.S degrees in control & instrumentation engineering from Changwon National University, Changwon, Gyeongnam Korea in 2006,2008, respectively. From 2006 to 2008 he was with the Power Conversion & System for RES Research Group ,Korea Electrotechnology Research Institute, as a researcher. And Power Electronics Application Team, Power & Industrial Systems R&D Center, Hyosung where he is currently a researcher. His main research interests are power electronic control of PV PCS, and power converter circuits.



Jeong-Joong Kim was born in Korea in 1981. He received the B.S. and M.S. degrees in Control & Instrument Engineering from Chang-won National University, Chang-won, Korea. Currently he is a researcher Engineer with Hyosung Power & Industrial Systems

R&D center. His main research interests are DC/DC & AC/DC converters.

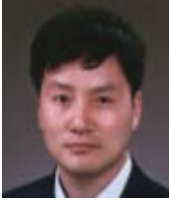

Eui-Ho Song received the B.S. degree in electrical engineering from Busan National University, Korea, in 1988, and the M.S. and Ph.D. degrees in electrical engineering from the POSTECH, Korea, in 1990 and 1993, respectively. From 1993 to 1996 he developed SMPS at the Samsung Electromechanics Co. Since 1996, he has joined at the Dept. of Control and Instrumentation Eng. in Changwon National University, where he is currently a Professor. His research interests include SMPS, FACTS and control of the power electronic systems.